



FOUNDED IN 2003

FOLDING

movable walls and folding partitions



we Develop
we Produce
we Deliver
we Install

Production of movable walls and folding partitions



INNOVATION FOR YOUR INTERIOR

A modern space division system will allow you to manage the room and transform it to your needs.

- ▶ any trajectory of the installation of the wall
- ▶ lots of panel parking options



Divide the space and create several independent rooms with a separate entrance.

- ▶ single-leaf and double-leaf doors
- ▶ mechanical and automatic movement of panels

In just a few seconds, remove the wall to the side and combine the rooms into one large space.

- ▶ easy opening
- ▶ silent movement of panels



Divide the room into men's and women's rooms.

- ▶ sound insulation up to 55 dB
- ▶ various panel design options

- FOLDING Co started in 2003
- Established a factory in 2013
- We are improving for you every decade!



COMPARISON OF OUR PRODUCTS

	Folding partitions			Movable walls				
Parameter	NORMA 80	NORMA 80. Top&Bottom rail	NORMA 40	NORMA 100	"Floating" NORMA 100	NORMA 80	NORMA 40 Coming soon!	"Floating" NORMA 100. Semi-auto, auto
	40-47 dB	40-47 dB	Up to 30 dB	40-52 dB	40-55 dB	40-47 dB	Up to 30 dB	40-55 dB
	18-39 kg/m ²	18-39 kg/m ²	20 kg/m ²	28-66 kg/m ²	28-55 kg/m ²	18-39 kg/m ²	25 kg/m ²	28 kg/m ²
	83 mm	83 mm	40 mm	106 mm	107 mm	83 mm	40 mm	107 mm
	2000-5900 mm	2000-5900 mm	2000-4000 mm	2400-5900 mm	2400-12000 mm	2000-5900 mm	2000-4000 mm	2400-12000 mm
	500-1020 mm	500-1020 mm	500 - 1020 mm	700-1240 mm	500-1240 mm	500 - 1240 mm	500 - 1020 mm	500-1240 mm
	Aluminum	Aluminum	Aluminum	Aluminum	Aluminum and steel	Aluminum	Aluminum	Aluminum and steel
	Built into the structure, 10-16 mm	Built into the structure, 10-16 mm	Built into the structure, 10 mm	Built into the structure, 16 mm	Removable boards, 16 mm	Built into the structure, 10-16 mm	Built into the structure, 10 mm	Removable boards, 16 mm
	Optional up to 15 minutes	Optional up to 15 minutes	Optional up to 15 minutes	Optional up to 15 minutes	Optional up to 15 minutes	Optional up to 15 minutes	Optional up to 15 minutes	Optional up to 15 minutes
	aluminum with magnetic latches	aluminum with magnetic latches	Anodized aluminum with magnetic in last panel	Anodized aluminum	Anodized aluminum with magnetic seals	Anodized aluminum with magnetic latches	Anodized aluminum with magnetic in last panel	Anodized aluminum with magnetic seals
	Last panels functions as a door	Last panels functions as a door	One panel functions as a door	Single and double door	Single and double door	One panel functions as a door	-	Single and double door
	Imposts 100 mm	Imposts 100 mm	All-glass version possible	Imposts 200 mm	Imposts 200 mm	Imposts 100 mm	Imposts 200 mm	Imposts 100 mm

FOLDING PARTITIONS NORMA 80

PRODUCT DESCRIPTION

- Sound insulation structure of the "folding" type
- Consisting of panels fastened together with hinges
- The partition moves along the ceiling track
- Panels retract into parking lot

Vertical section

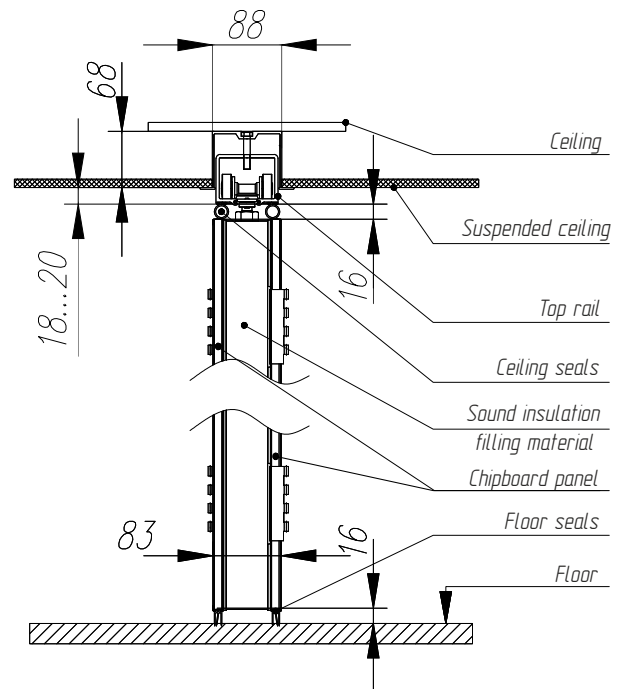

WE MANUFACTURE 2 TYPES OF PARTITIONS (BY FOLDING TYPE)

From wall to wall

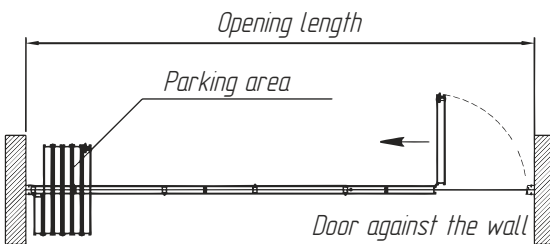

From the center to the walls

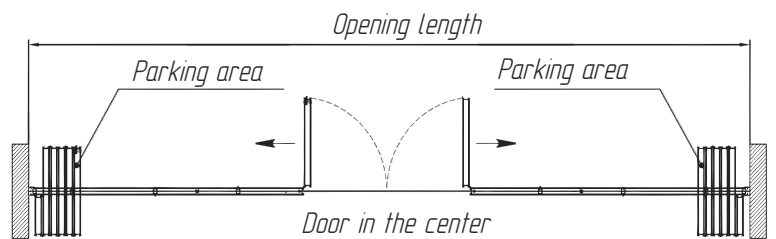

TECHNICAL SPECIFICATIONS



- Sound insulation
40, 43 and 47 dB.

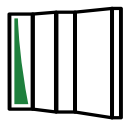

- Panel thickness:
83 mm.



- Panel height
2,000-5,900 mm.



- Weight:
18-39 kg/m²

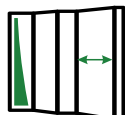

- Panel width:
500-1020 mm.



- Maximum length of one
partition: 9 000 mm.

BENEFITS

- Low specific weight (from 18 kg/m²)
- Replenishment of horizontal and vertical door opening irregularities
- Minimum production time (from 7 days)
- Due to the installation of magnets at the ends of the panels, the partition forms a straight line, and the unfolding takes a few seconds)

FOLDING PARTITION NORMA 80 with top and bottom rail

PRODUCT DESCRIPTION

- Sound insulation structure of the "folding" type
- Consisting of panels fastened together with hinges
- The partition moves along the top and bottom rails
- Panels retract into parking lot
- The floor track and the lower roller carry the main load

Vertical section

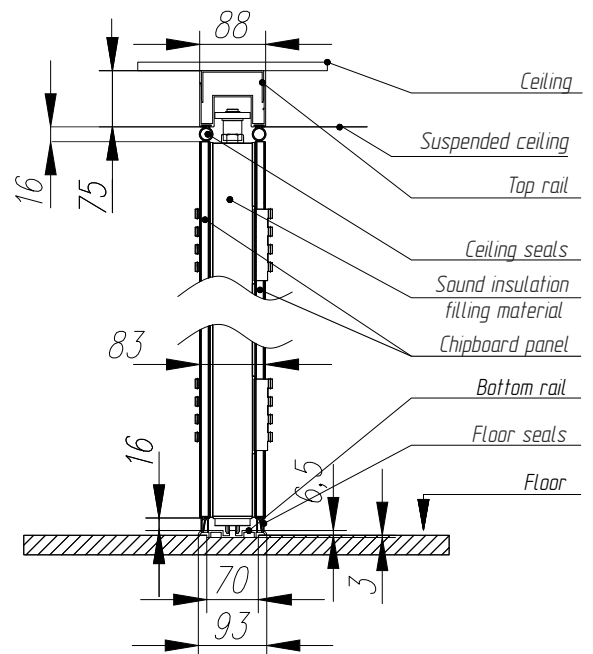

WE PRODUCE 4 TYPES OF PARTITIONS

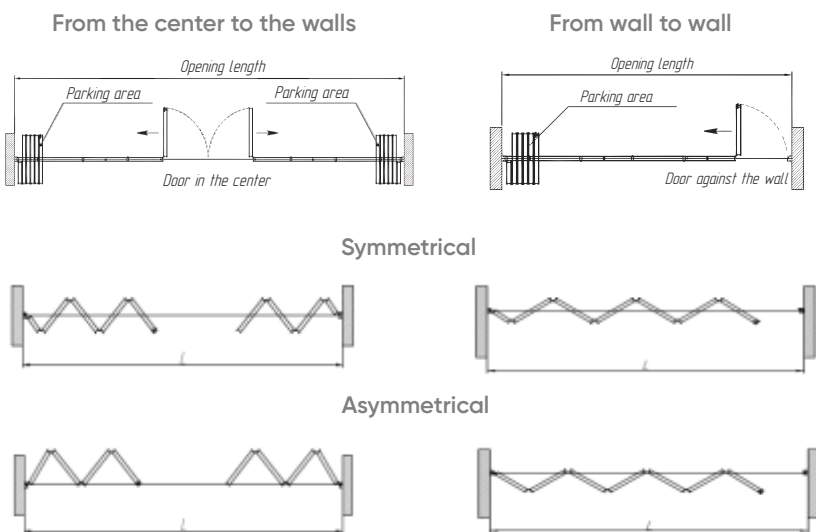

TECHNICAL SPECIFICATIONS

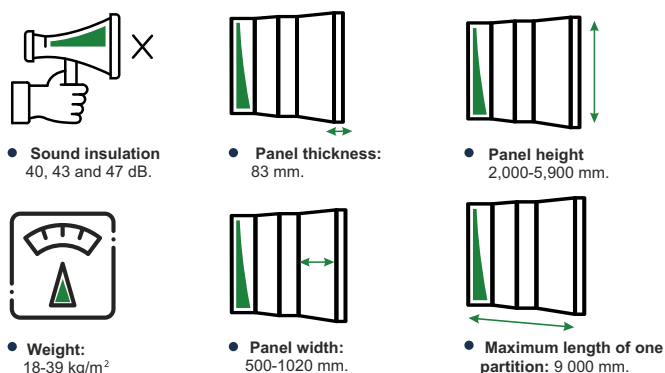

BENEFITS

- 1-2 leaf door free of charge
- Top and bottom rail track reduces the ceiling load
- Possibility of fabrication of asymmetrical version.
- Magnetic inserts make the partition semi-automatic
- The control handle is hidden in the end of the structure

FOLDING PARTITION NORMA 40

PRODUCT DESCRIPTION

- Sound insulation structure of the "folding" type
- Consisting of panels fastened together with hinges
- Move on the ceiling rail one by one
- Panels retract into parking lot
- Panel thickness is only 40 mm

Vertical section

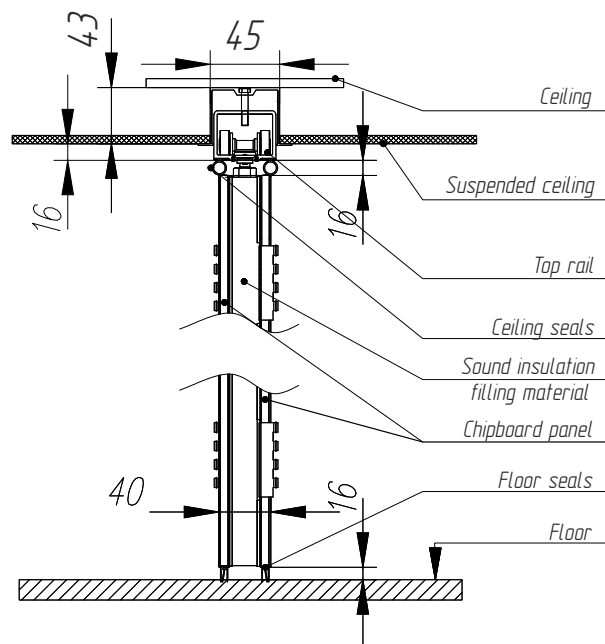

WE PRODUCE 2 TYPES OF PARTITIONS

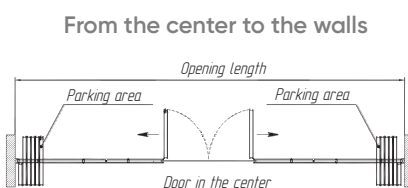
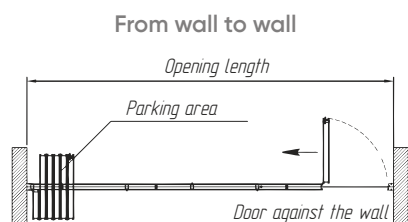

TECHNICAL SPECIFICATIONS



- Sound insulation 30 dB.

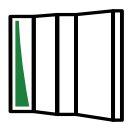

- Panel thickness: 40 mm.



- Panel height 2,000-4,000 mm.



- Weight: 20 kg/m²

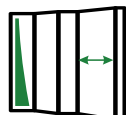

- Panel width: 500-1020 mm.

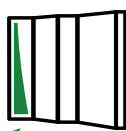

- Maximum length of one partition: 8 000 mm.

BENEFITS

- 1 leaf door free of charge
- Magnetic inserts in last panels
- Pins are built into every second panel and provide structural rigidity
- Thin and light panels

MOVABLE WALL NORMA 100

PRODUCT DESCRIPTION

- Sound insulation structure with individual panels
- Move on the ceiling rail one by one
- 11 types of parking
- Doorsill seals are mechanically extended into the floor and ceiling
- Construction includes one telescopic panel

Horizontal section of the telescopic panel



Vertical section:

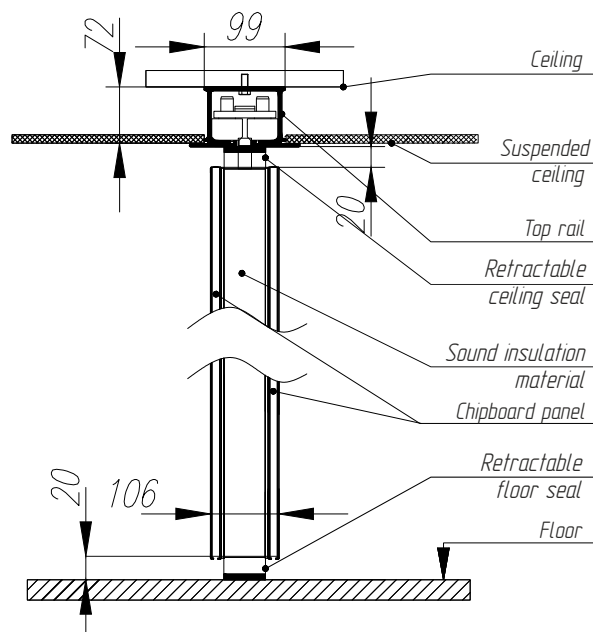

BENEFITS

- Panel fixing handle rotates in one half- turn
- Availability of one-leaf or two-leaf door in one of the panels
- Wide choice of parking areas
- Variability in the choice of sound insulation type
- Low specific weight



TECHNICAL SPECIFICATIONS

- Sound insulation: 40-52 dB.
- Panel thickness: 106 mm.
- Panel height: 2,200-5,900 mm.

- Weight: 28-66 kg/m²
- Panel width: 750-1240 mm.
- Maximum length of one partition: unlimited

MAIN PARKING SYSTEMS

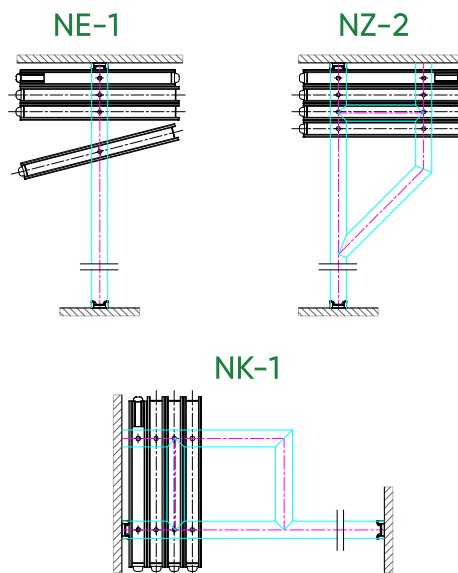

MOVABLE WALL "FLOATING" NORMA 100

PRODUCT DESCRIPTION

- Sound insulation structure with individual "floating" panels
- Move on the ceiling rail one by one
- Each panel consists of a main steel frame with a sound insulation layer and two facing sheets.
- Doorsill seals are mechanically extended into the floor and ceiling
- Construction includes one telescopic panel

Panel horizontal section:

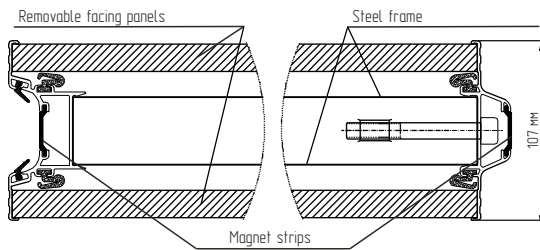

Panel vertical section:

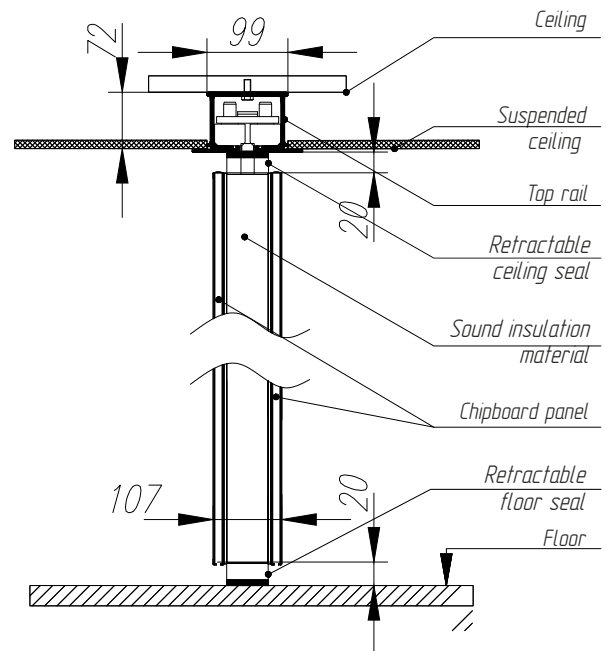

BENEFITS

- Maximum sound insulation of all products (up to 55 dB)
- Quick design change on the installation site
- Height up to 12 meters
- Serviceability
- Affixment of panels to each other with a magnetic strip at the end of the structure



TECHNICAL SPECIFICATIONS

- **Sound insulation:** 40-55 dB.
- **Panel thickness:** 107 mm.
- **Wall height:** 2400-12000 mm.
- **Weight:** 28-55 kg/m²
- **Panel Width:** 500-1500 mm. Standard width: 1240 mm.
- **Max length** – unlimited

MAIN PARKING SYSTEMS

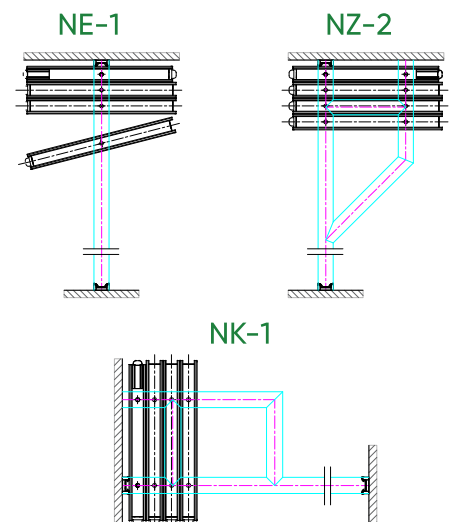

MOVABLE WALL NORMA 80

PRODUCT DESCRIPTION

- Sound insulation structure with individual panels
- Move on the ceiling rail one by one
- 9 types of parking
- Tongue and groove inserts provide structural rigidity
- Magnetic latches at the ends of the panels

Tongue and groove

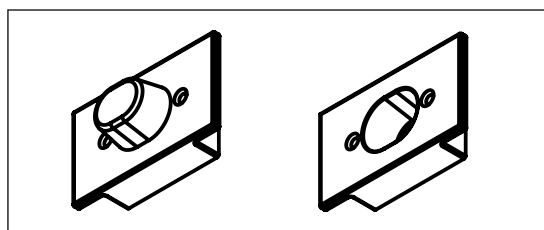

Panel vertical section:

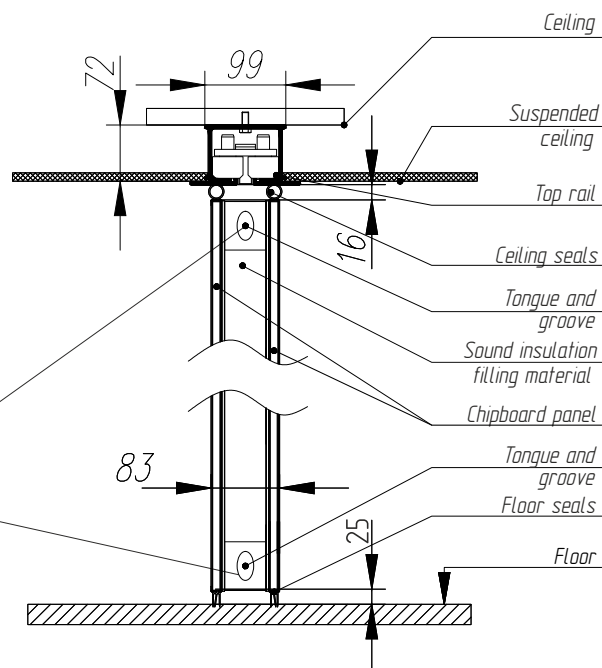

BENEFITS

- High level of sound insulation with a thickness of 83 mm
- 1-2-leaf door free of charge
- Thin lightweight panels
- Minimization of parking space
- Maximum glazing area
- Minimal specific weight



TECHNICAL SPECIFICATIONS

- **Sound insulation:** 40, 43 and 47 dB.
- **Panel thickness:** 83 mm.
- **Panel height:** 2,000-5,900 mm.
- **Weight:** 18-39 kg/m²
- **Panel width:** 500-1500
- **Max length:** unlimited
- **Framing width:** 150 mm
- **Standard panels** move along the ceiling track independently and one by one.
- **The door panel** moves in tandem with one standard, hinged together.

MAIN PARKING SYSTEMS

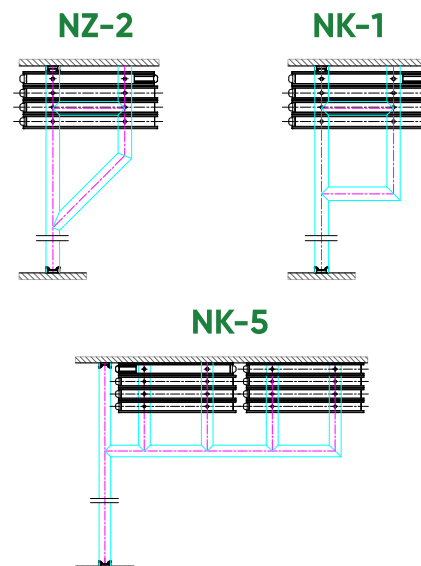

MOVABLE WALL NORMA 40

PRODUCT DESCRIPTION

- Sound insulation structure with individual panels
- Move on the ceiling rail one by one
- 9 types of parking
- Tongue and groove inserts provide structural rigidity
- Magnetic latches at the ends of the panels



Panel vertical section:

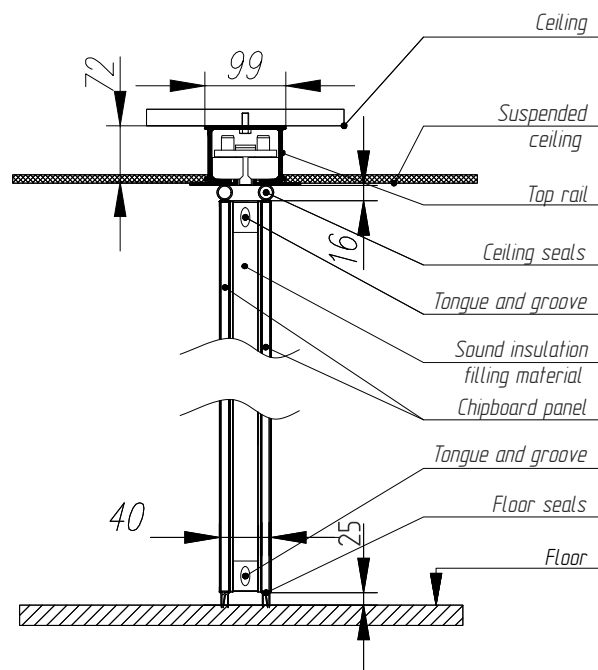

BENEFITS

- High level of sound insulation with a thickness of 40 mm.
- 1-2-leaf door free of charge
- Thin lightweight panels
- Minimization of parking space
- Minimal specific weight

TECHNICAL SPECIFICATIONS

- **Sound insulation:** 30 dB.
- **Panel thickness:** 40 mm.
- **Panel height:** 2,000-4,000 mm.
- **Weight:** 25 kg/m²
- **Panel width:** 500-1240 mm
- **Max length:** unlimited
- **Framing width:** 200 mm
- **Standard panels** move along the ceiling track independently and one by one.
- **The door panel** moves in tandem with one standard, hinged together.

MAIN PARKING SYSTEMS

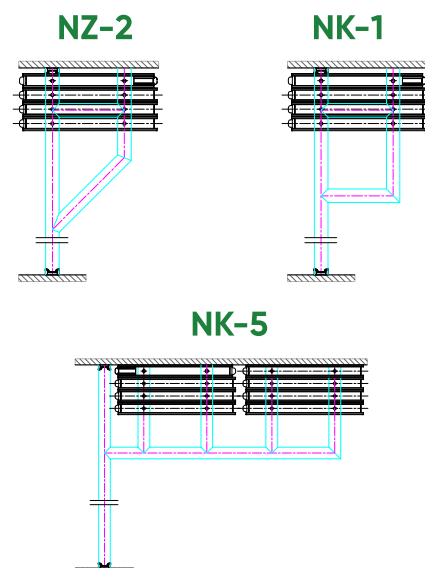

MOVABLE WALL “FLOATING” NORMA 100

Semi-auto

PRODUCT DESCRIPTION

- Sound insulation structure with individual “floating” panels
- Move on the ceiling rail one by one
- Each panel consists of a main steel frame with a sound insulation layer and two facing sheets.
- Doorsill seals are mechanically extended into the floor and ceiling
- Construction includes one telescopic panel
- The transformer unit automatically extends the seals to the floor and ceiling

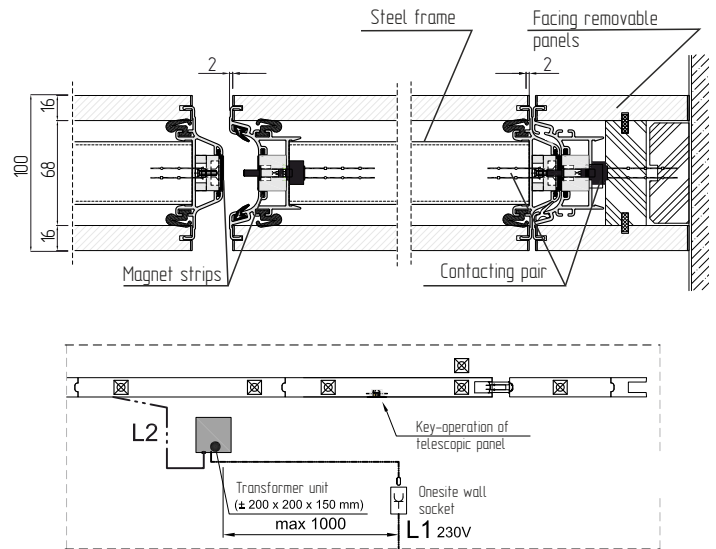

Panel horizontal section:



BENEFITS

- Maximum sound insulation of all products (up to 55 dB)
- Quick design change on the installation site
- Height up to 12 meters
- Serviceability
- Affixment of panels to each other with a magnetic strip at the end of the structure
- Semi-automatic opening

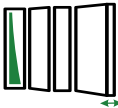
TECHNICAL SPECIFICATIONS

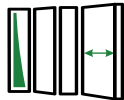
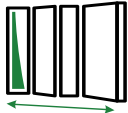
- 
 - **Sound insulation:** 40-55 dB.
- 
 - **Panel thickness:** 107 mm.
- 
 - **Wall height:** 2400-12000 mm.
- 
 - **Weight:** 28-55 kg/m²
- 
 - **Panel Width:** 500-1240 mm. Standard width: 1240 mm.
- 
 - **Max length** – unlimited

MAIN PARKING SYSTEMS

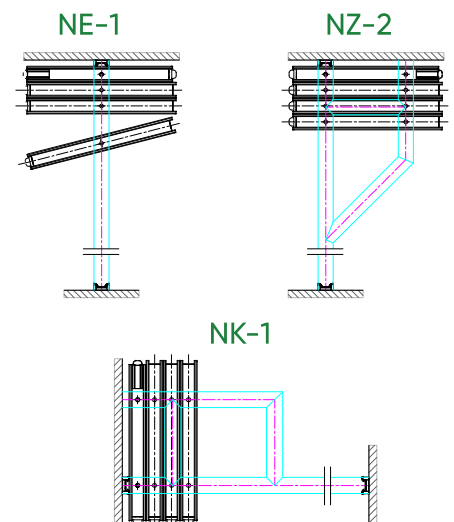

OUR PRODUCTS ARE INSTALLED WORLDWIDE IN VARIOUS LOCATIONS!



Regional Corporate Bank "Pohjolan Osuuspankin" in Rovaniemi, Finland



Irina Viner-Usmanova Rhythmic Gymnastics Center, Moscow, Russia



Educational center "Sirius", Sochi, Russia



Embassy of the Russian Federation in the Republic of Panama



Office of KMK "Astana Motors", Almaty, Kazakhstan



Neurology Clinic "Epijay", St. Petersburg, Russia



High school №25, Aktau, Kazakhstan



Dance center "Revolution", Moscow, Russia



Manufacturing plant, Moscow, Russia



Hotel Park Inn, St. Petersburg, Russia



High school №2097, Moscow, Russia



Office of the Russian-Japanese enterprise "Hokkaido Developers Group", Yuzhno-Sakhalinsk, Russia

CONTACTS

FOLDING Company LLC, 2 Voskova Str., letter Я, Sestroretsk, Saint Petersburg, 197706;

102 Mira Ave., of. 102, build.38, Moscow, 129626.

Calls within Russia
+7 (800) 775-26-91

Finland
+358 (41) 575-93-38

Israel
+972 (51) 228-91-02

www.folding.ae
sales@folding.ae